

RECTANGULAR DUCT SILENCER RAAC48

USAGE - The NOISESTOP RAAC 48 Rectangular Duct Silencer is an absorptive baffle attenuator which converts duct borne noise energy into thermal energy within the acoustic media contained in the baffle elements. The RAAC Rectangular Duct Silencer range has been specifically designed for use in ducted ventilation and air conditioning systems. The main applications of RAAC Silencers are the reduction of mechanical noise generated by the primary air circulation fan and the elimination of secondary regenerated noise from terminal units, mixing chambers or pressure reducing devices. NOISESTOP RAAC Rectangular Duct Silencer are also used to reduce the level of external noise (aircraft, traffic etc.) entering a building, to control and contain the noise of enclosed machinery (pumps, compressors, generating sets etc.) and the elimination of speech interference, transferred by interconnecting ducting, across office walls and partitions. Selection of the correct RAAC Silencer is by subtraction of the Dynamic Insertion Loss from the source sound level with corrections being made for the natural attenuation of the duct system to obtain the established space noise criteria. NOISESTOP engineers are available on request to assist you in the proper selection of silencers for your particular requirements.

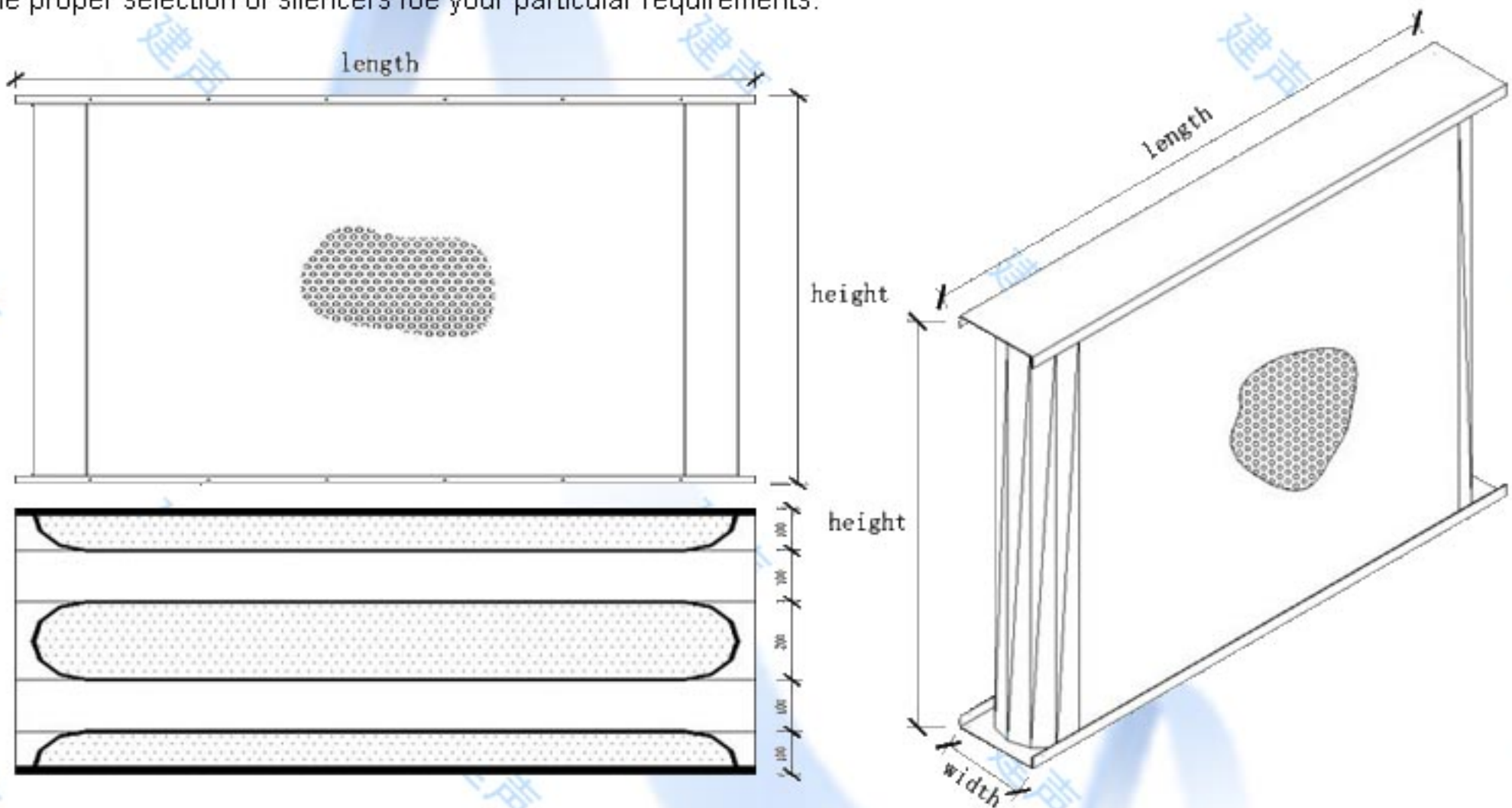

CONSTRUCTION - The NOISESTOP RAAC 48 Rectangular Duct Silencer has inter-baffle separation of 175mm and the individual baffle elements are 200mm wide. This gives a modular width of 375mm and with this combination the silencer gives high attenuations over a short silencer length. An increase in duct cross sectional area may be required to optimize the silencer's pressure loss and self-noise. RAAC 48 Silencers are therefore supplied with duct widths equal to any multiple of 375mm, with duct heights to suit the customer requirements and in only one of six standard lengths (900,1480,1500,1800,2100and2400mm). NOISESTOP RAAC standard Rectangular Duct Silencers are constructed from high quality galvanised sheet steel. The casings are lock-formed and conform to the latest HVCA ductwork standard. All joints are sealed with a suitable mastic sealant and the baffle elements and end flanges are retained by sealed fixings. In this standard form NOISESTOP RAAC Silencer can withstand duct static pressures up to 1250 pascals. For higher static pressures the casing of the silencer is constructed from mild steel sheet, all joints being continuously seam welded. Each silencer is normally supplied with pre-drilled mild steel end flanges and drilling details are supplied at the time of order but can be made available separately on request. Alternatively silencers can be supplied with undrilled flanges or spigot connections where required. The baffle elements contain inert, non-flammable, mineral wool retained in a galvanised sheet steel casing. The inlet profile of the baffle is aerodynamically shaped to minimize pressure losses and the side faces of the baffle are formed from stiffened perforated metal to ensure stability and integrity of the acoustic media even under adverse airflow conditions. The acoustic media can be further protected for special applications such as supplied air to clean rooms or operating theatres or extracting from kitchens, laboratories or highly contaminated industrial process areas. For such special applications a NOISESTOP engineer should be consulted to establish the most appropriate treatment.

TYPICAL SPECIFICATIONS - NOISESTOP RAAC Rectangular Duct Silencers shall be installed in the positions indicated on the drawings to maintain the acoustic criteria in the specification. The silencers shall have galvanised sheet steel casings with drilled, mild steel, end flanges. The inlet section of the baffle elements shall be aerodynamically shaped. The acoustic media shall be inert, non-flammable mineral wool. The acoustic media shall be retained in position by perforated, galvanised steel face sheets stiffened to maintain the integrity of the baffle element even under adverse airflow conditions

NOISESTOP

RECTANGULAR DUCT SILENCER RAAC48

Aerodynamic – It may be necessary to establish the correct size of silencer knowing that a certain pressure loss is required across the silencer for a given volume of air. In this case the duct face velocity is read off the chart opposite and the silencer dimensions established from the formula below:

$$\text{Airflow (Q)} = \text{Duct Area (A)} \times \text{Duct Face Velocity}$$

Conversely for a known duct size and airflow the pressure loss across the silencer can be obtained from the chart opposite.

Selection Example: Assuming the airflow is 5m³/sec and the maximum allowable pressure loss is 100 pascals. Assuming also that a 1200mm long silencer will meet the acoustic requirements by entering the chart opposite on the horizontal axis at 100 pascals, for a 1200mm long silencer, a duct velocity of 11.6m/sec is obtained. The duct area is then given as $A = Q/v = 5/11.6 = 0.43\text{m}^2$. If a width of 750mm is now selected (being 6x modular width) the height will be 573mm and the final selection will be as shown below:

Type RAAC48/1200 Silencer - 750mmx573mmx1200mm long

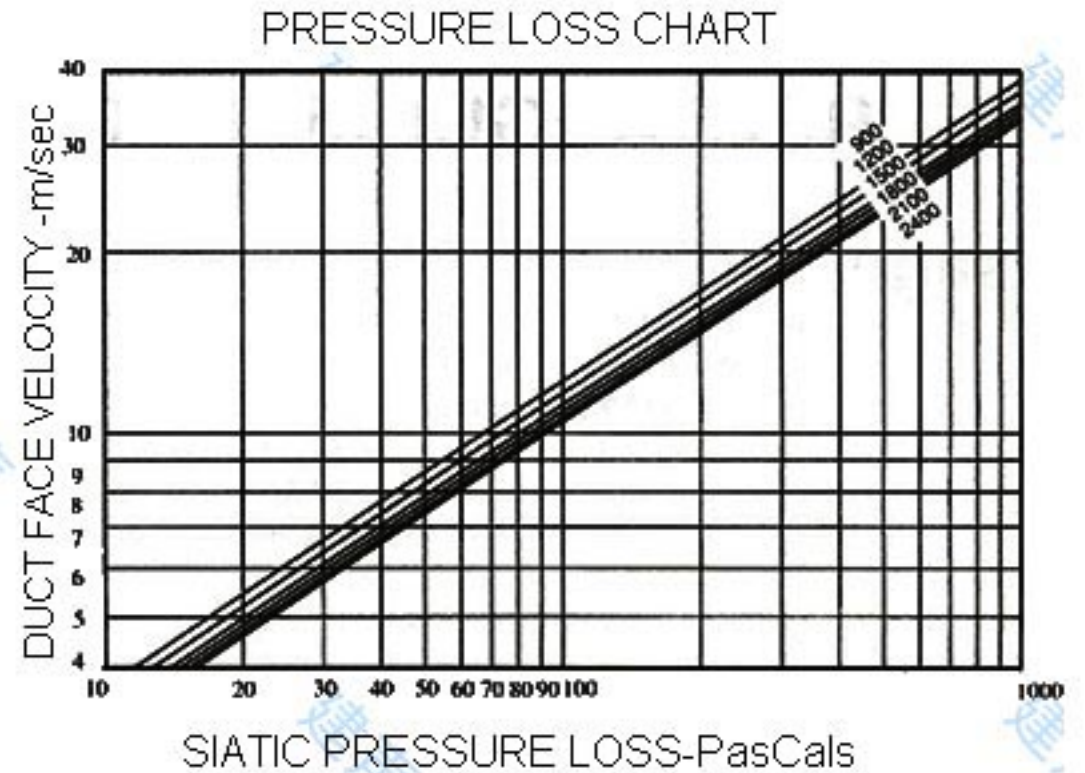

Length (mm)	Dynamic Insertion Loss (dB) at Octave band centres(Hz)								Duct Velocity (m/sec)	Corrections to D.I.L. in dB for duct velocities greater than 12 metre/sec							
	63	125	250	500	1K	2K	4K	8K		63	125	250	500	1K	2K	4K	8K
900	2	5	11	18	25	24	18	8	+12	-2	-3	-6	-6	-5	-5	-5	-6
1200	3	6	14	24	30	31	22	11	+16	-2	-3	-3	-5	-5	-5	-6	-6
1500	4	9	17	30	35	37	30	12	+20	-4	-5	-6	-7	-7	-6	-5	-6
1800	4	12	20	33	39	40	32	15	-12	+1	+2	+2	+3	+3	+2	+2	+1
2100	5	15	24	38	44	46	35	18	-16	+2	+3	+3	+3	+3	+2	+2	+2
2400	6	18	26	42	45	48	38	20	-20	+2	+3	+4	+4+	+4	+3	+3	+2
									+ve velocities are for noise and airflow in the same direction and -ve velocities where noise and airflow are in opposite directions								
Duct Face Velocity (m/sec)	Silencer Self Noise in dB ref 10-12 watts for different velocities								The silencer self noise levels given in the table opposite are for a face area of 0.5m ² . For areas greater or smaller the dB corrections shown below should be applied								
	63	125	250	500	1K	2K	4K	8K									
5	43	41	41	42	39	41	39	33	face area(m ²) 0.1 0.3 0.75 1 3 5 10 corrections to PWL (dB) -7 -3 +2 +3 +7 +10 +13								
8	52	49	49	55	54	50	47	44									
10	58	54	53	58	61	54	54	49									
15	65	61	60	60	62	63	60	61									

PHYSICAL - NOISESTOP Rectangular Duct Silencers can be positioned at any point in a ductwork system consistent with good airflow and acoustic design considerations. The silencer performance may be compromised if the flow conditions immediately before or after the silencer location are excessively turbulent. For this reason it is recommended that a minimum length of straight ducting on both sides of the silencer be allowed equal to three times the largest duct dimension. When plantroom arrangements do not allow this minimum condition then it is advisable to incorporate turning or guide vanes into the duct design to ensure that the airflow is uniform across the silencer face area. The NOISESTOP RAAC48 Rectangular Duct Silencer has an approximate volumetric weight of 155kg/m³. Silencer should be installed onto angle or channel supports placed at right angles to the baffle elements across the width of the silencer. When lifting NOISESTOP RAAC48 Rectangular Duct Silencers into position on site it is important to ensure that the slings used are placed around the outside of the silencer casing and the silencer lifted with the baffle elements vertical. It is imperative that silencer not be lifted by their end flanges or by slinging through the internal airway passages. Silencer of large dimension (above a face of 1.5m²) can be supplied in modules for on site assembly. For individual requirements please consult an NOISESTOP engineer who will be pleased to assist you with your individual requirements.