

WOODACOUSTICS"活士" 吸音板

平板式吸音板
條柵型吸音板
8 / 24 / 90R

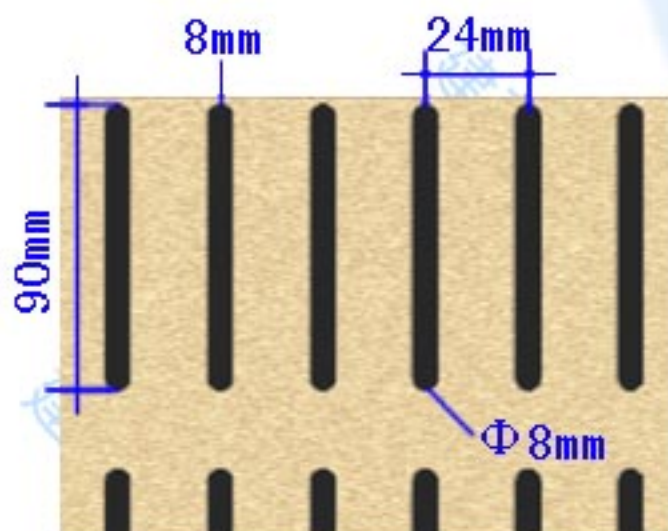

吸聲性能曲線圖

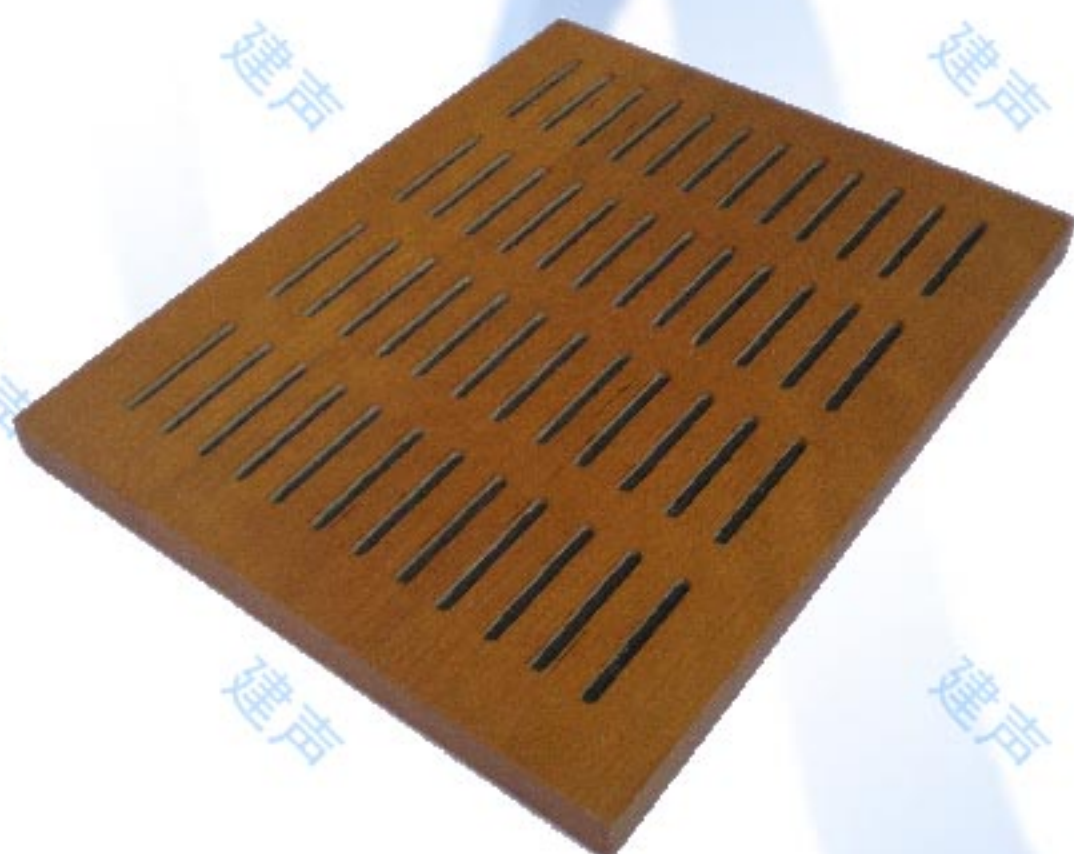
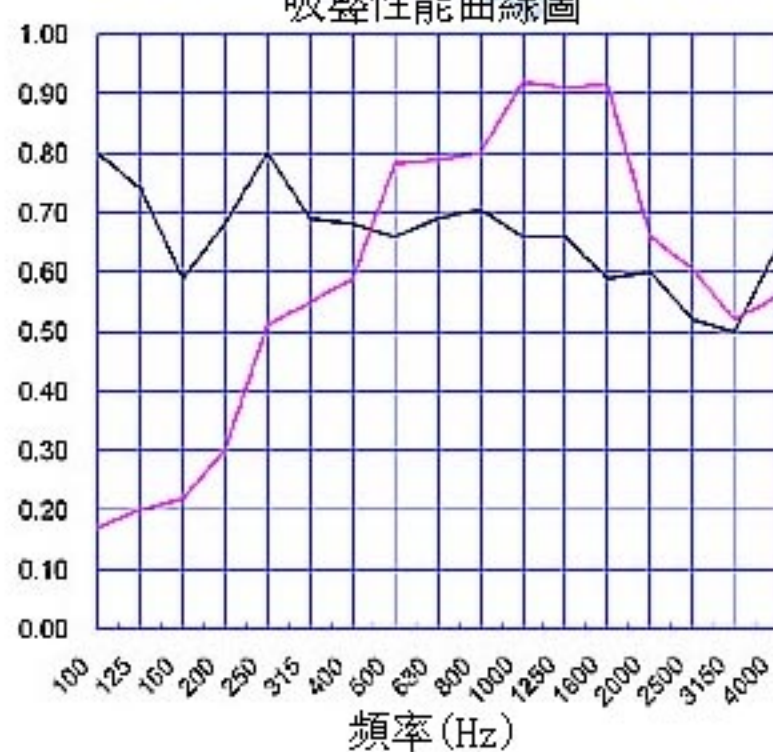

吸音系數	1/3 信頻程分析 (Hz)					
	125	250	500	1K	2K	4K
— A型	0.20	0.51	0.78	0.92	0.66	0.56
— B型	0.74	0.80	0.66	0.66	0.60	0.64

WOODACOUSTICS"活士" 吸音板

平板式吸音板
條柵型吸音板
2 / 6 / 500

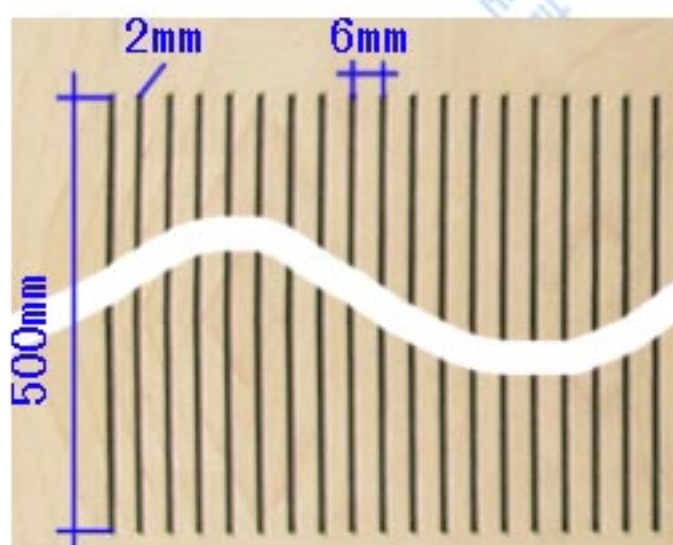
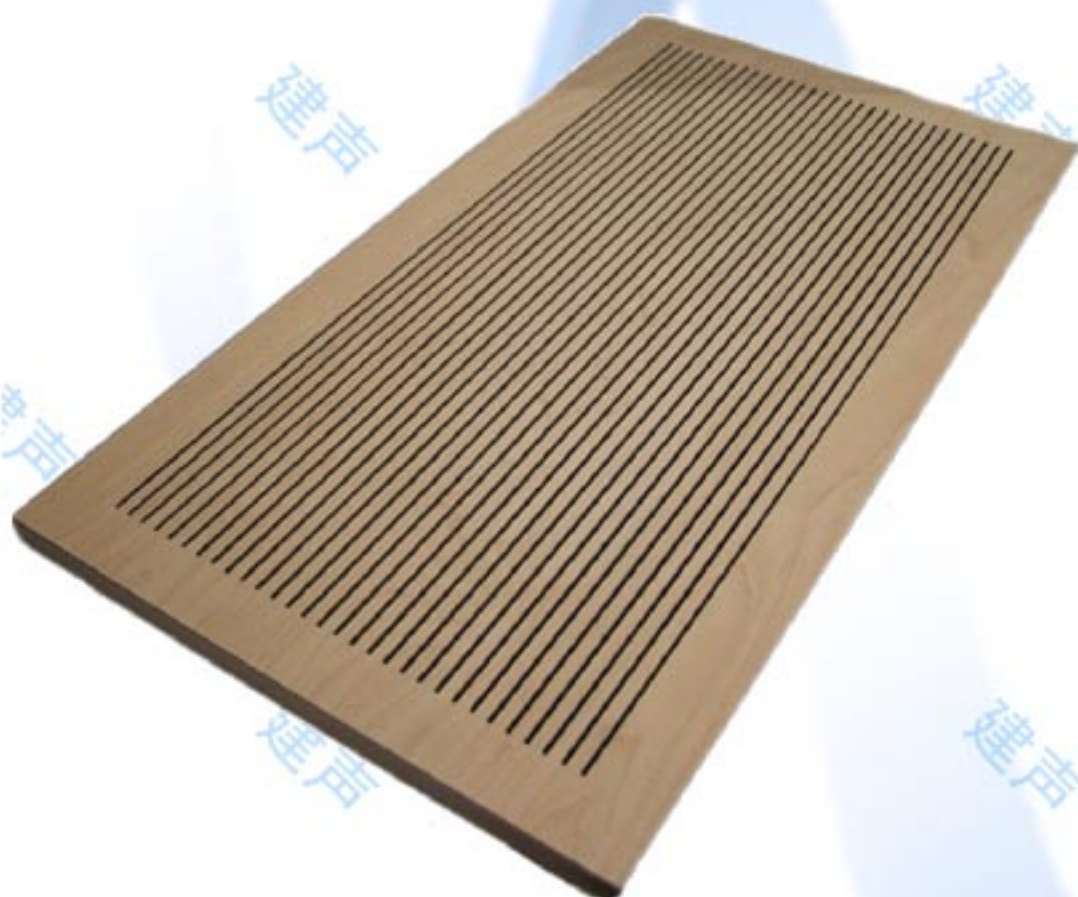

吸聲性能曲線圖

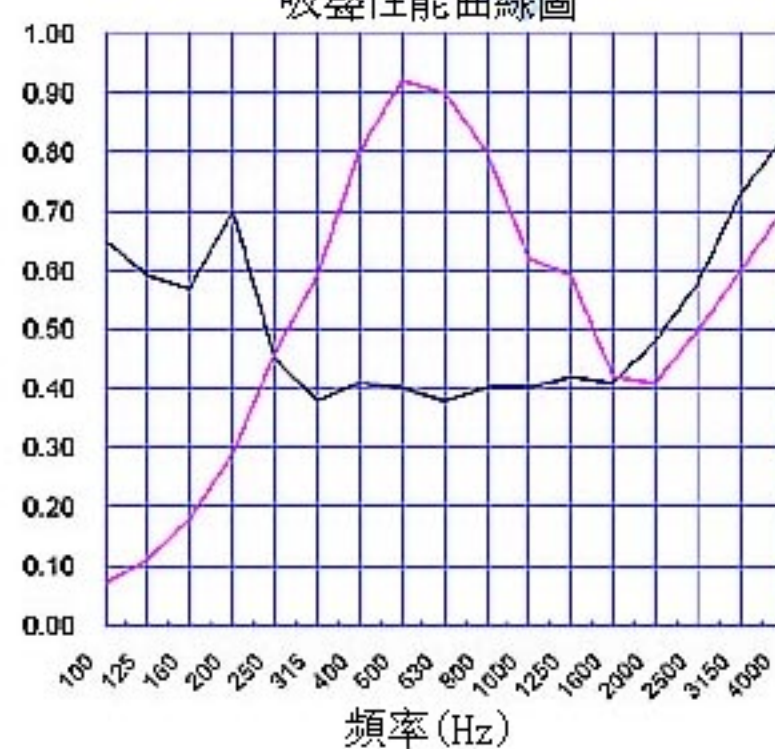

吸音係數	1/3 信頻程分析 (Hz)					
	125	250	500	1K	2K	4K
— A型	0.11	0.46	0.92	0.62	0.41	0.70
— B型	0.59	0.45	0.40	0.40	0.48	0.82

WOODACOUSTICS"活士" 吸音板

平板式吸音板
條柵型吸音板
2 / 9 / V30

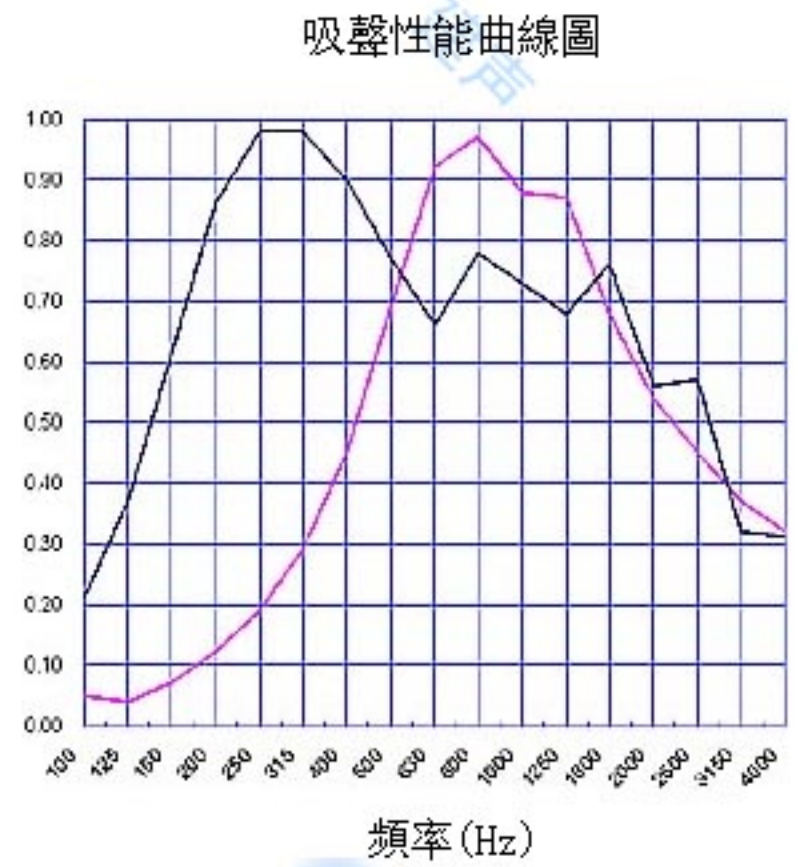
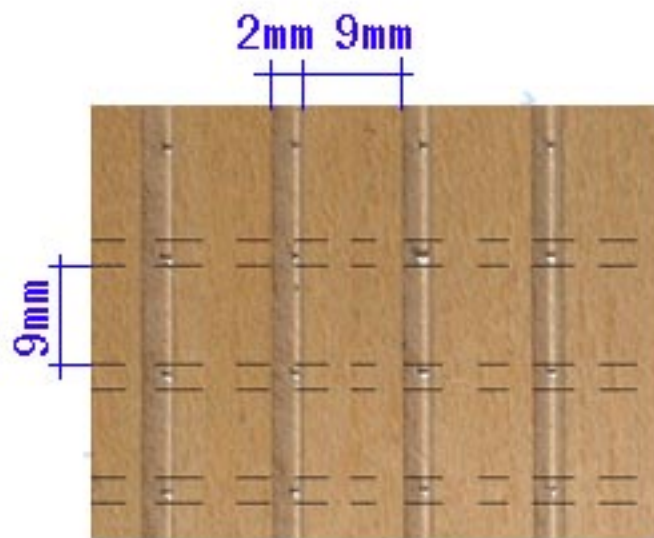
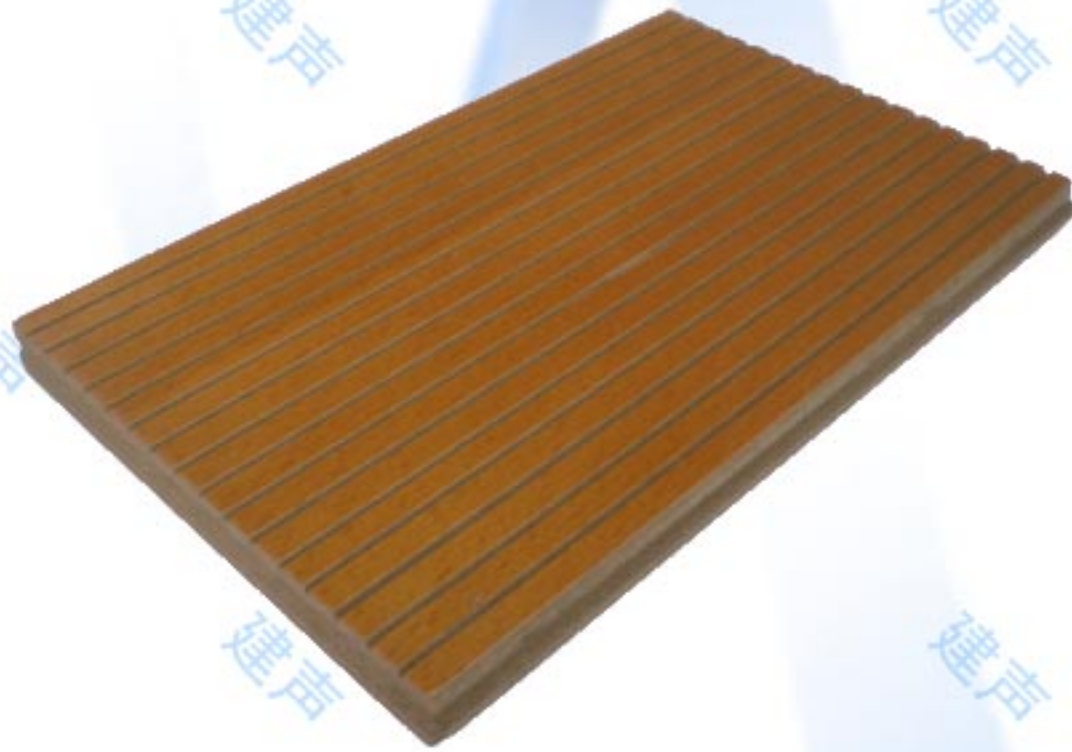

吸音系數	1/3 信頻程分析 (Hz)					
	125	250	500	1K	2K	4K
— A型	0.04	0.19	0.69	0.88	0.54	0.32
— B型	0.37	0.98	0.77	0.73	0.56	0.31



WOODACOUSTICS"活士" 吸音板

平板式吸音板
條柵型吸音板
3 / 7 / 90

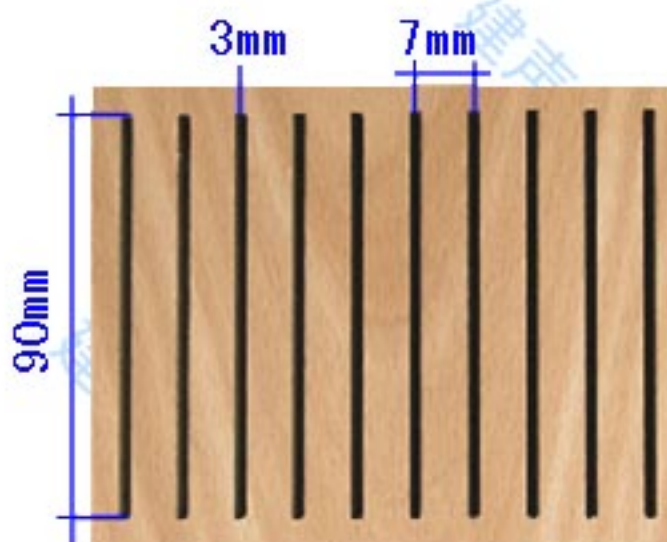

吸聲性能曲線圖

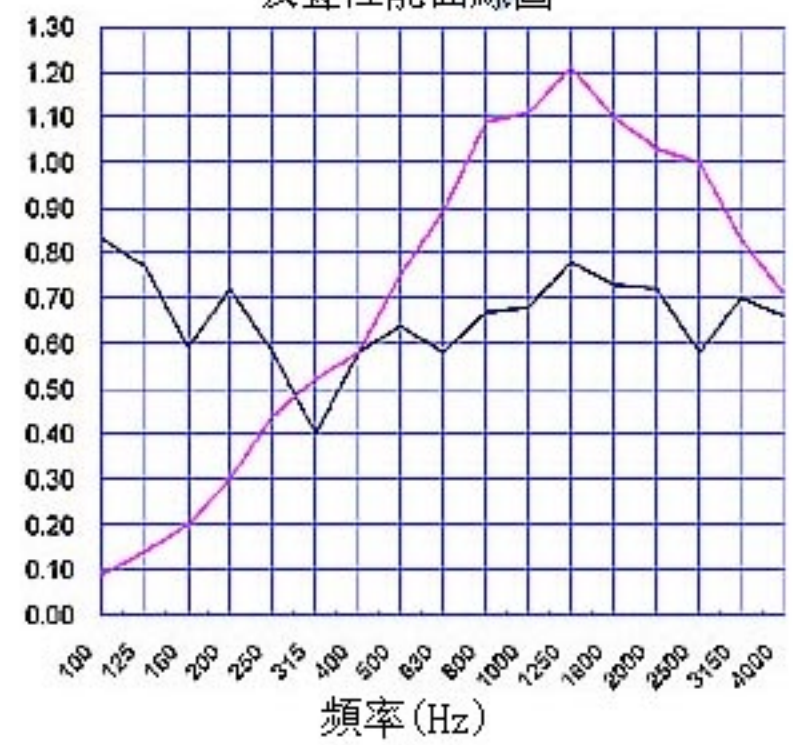

吸音系數	1/3 信頻程分析 (Hz)					
	125	250	500	1K	2K	4K
— A型	0.14	0.44	0.75	1.11	1.03	0.71
— B型	0.77	0.58	0.64	0.68	0.72	0.66